

GOVT CO-ED POLYTECHNIC
BYRON BAZAR RAIPUR (C.G.)

LAB MANUAL

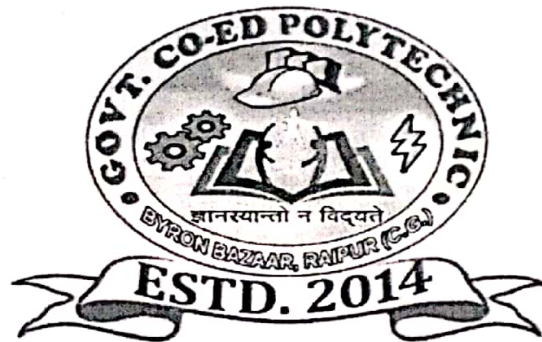

Year & Semester : 1st Year / 1st & 2nd Semester

2000190(015) - APPLIED PHYSICS LAB

CONTENT

S. NO.	NAME OF EXPERIMENT	PAGE NO.
1.	Determine dimension of given object by using Vernier callipers	1
2.	Determine dimension of given object by using Screw gauge .	3
3.	Determining the value of g by Simple pendulum method	5
4.	Determine the resistance of given wire by Meter bridge	7
5.	Refraction through glass slab	9
6.	Refraction through prism	11
7.	Draw magnetic field of lines of a bar magnet	13

EXPERIMENT NO :- 1

DETERMINING THE DIMENSION BY USING VERNIER CALLIPERS

AIM :-

Use of Vernier Callipers to

- (i) measure diameter of a small spherical/cylindrical body,
- (ii) measure the dimensions of a given regular body of known mass and hence to determine its density.
- (iii) measure the internal diameter and depth of a given cylindrical object like beaker/glass/calorimeter and hence to calculate its volume.

APPARATUS AND MATERIAL REQUIRED

Vernier Callipers, Spherical body, such as a pendulum bob or a glass marble, rectangular block of known mass and cylindrical object like a beaker/glass/calorimeter

DESCRIPTION OF THE MEASURING DEVICE

A Vernier Calliper has two scales—one main scale and a Vernier scale, which slides along the main scale. The main scale and Vernier scale are divided into small divisions though of different magnitudes. The main scale is graduated in cm and mm. It has two fixed jaws, A and C, projected at right angles to the scale. The sliding Vernier scale has jaws (B, D) projecting at right angles to it and also the main scale and a metallic strip (N). The zero of main scale and Vernier scale coincide when the jaws are made to touch each other. The jaws and metallic strip are designed to measure the distance/ diameter of objects. Knob P is used to slide the Vernier scale on the main scale.

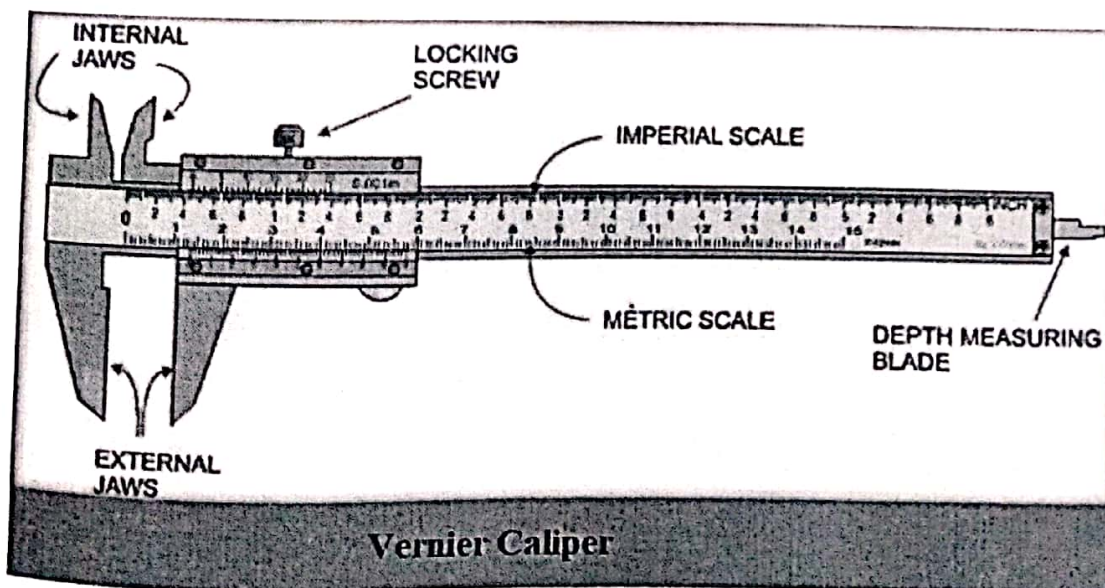

PRINCIPLE :

The difference in the magnitude of one main scale division (M.S.D.) and one vernier scale division (V.S.D.) is called the least count of the instrument, as it is $(n - 1)$ M.S.D.

(i) Least count of Vernier Callipers (Vernier Constant) 1 main scale division (MSD) = 1 mm = 0.1 cm

(ii) Number of vernier scale divisions, $N = 10$

(iii) 10 vernier scale divisions = 9 main scale divisions

(iv) 1 vernier scale division = 0.9 main scale division

(v) Vernier constant = (1 main scale division - 1 vernier scale division) = $(1 - 0.9)$ main scale division = 0.1 mm = 0.01 cm

(vi) Alternatively, 1MSD Vernier constant = N 1 mm = 10 Vernier constant (VC) = 0.1 mm = 0.01

(vii) Zero error and its correction When the jaws A and B touch each other, the zero of the Vernier should coincide with the zero of the main scale. If it is not so, the instrument is said to possess zero error.

OBSERVATION TABLE :-

Dimension	S. no.	Main scale reading (M) cm/mm	Number of coinciding Vernier division (N)	Vernier scale reading $V = N \times V'$	Measured Dimension $M + V$ (cm/mm)
Length (l)					
Breadth (b)					

Where V' = Least count of vernier scale .

RESULT :

Length of given object = _____ cm/mm

Depth of given object = _____ cm/mm

EXPERIMENT NO :- 2

DETERMINING THE DIMENSION BY USE OF SCREW GAUGE .

AIM :-Use of screw gauge to

- (a) measure diameter of a given wire
- (b) measure thickness of a given sheet
- (c) determine volume of an irregular lamina.

APPARATUS AND MATERIAL REQUIRED:

Wire, metallic sheet, irregular lamina, millimetre graph paper, pencil and screw gauge.

DESCRIPTION OF APPARATUS :

you are usually able to measure length accurately up to 0.1 mm. More accurate measurement of length, up to 0.01 mm or 0.005 mm, may be made by using a screw gauge. As such a Screw Gauge is an instrument of higher precision than a Vernier Callipers. You might have observed an ordinary screw .There are threads on a screw. The separation between any two consecutive threads is the same. The screw can be moved backward or forward in its nut by rotating it anticlockwise or clockwise.

The distance advanced by the screw when it makes its one complete rotation is the separation between two consecutive threads. This distance is called the Pitch of the screw. It is usually 1 mm or 0.5 mm. It has a screw 'S' which advances forward or backward as one rotates the head C through ratchet R. There is a linear scale 'LS' attached to limb D of the U frame. The smallest division on the linear scale is 1 mm (in one type of screw gauge). There is a circular scale CS on the head, which can be rotated. There are 100 divisions on the circular scale. When the end B of the screw touches the surface A of the stud ST, the zero marks on the main scale and the circular scale should coincide with each other.

PRINCIPLE :-

The linear distance moved by the screw is directly proportional to the rotation given to it. The linear distance moved by the screw when it is rotated by one

division of the circular scale, is the least distance that can be measured accurately by the instrument. It is called the least count of the instrument.

$$\text{Least count} = (\text{Pitch} / \text{No. of division on circular scale})$$

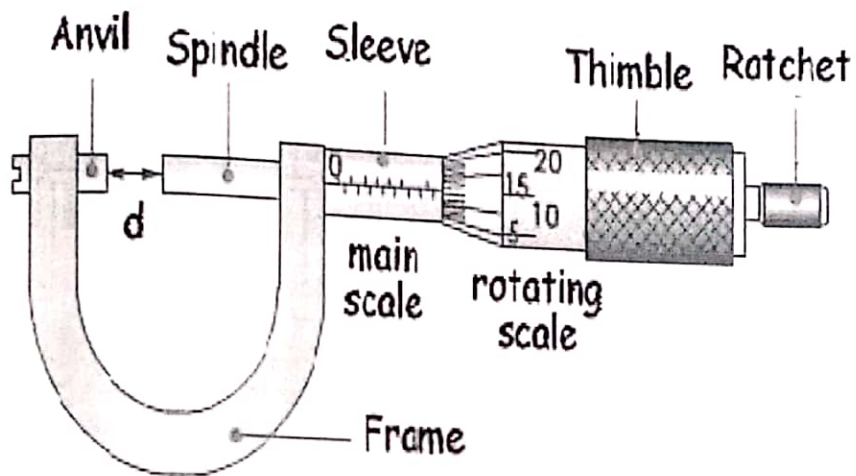

For example for a screw gauge with a pitch of 1mm and 100 divisions on the circular scale. The least count is = $1 \text{ mm} / 100 = 0.01 \text{ mm}$

Result :-

Diameter of given wire = _____ mm

EXPERIMENT NO:- 3

DETERMINING THE VALUE OF g BY USING THE SIMPLE PENDULUM

AIM:-

Using a Simple Pendulum finding value of g (gravitational acceleration).

APPARATUS AND MATERIAL REQUIRED

Clamp stand; a split cork; a heavy metallic (brass/iron) spherical bob with a hook; a long, fine, strong cotton thread/string (about 2.0 m); stop-watch; metre scale, graph paper, pencil, eraser.

DESCRIPTION OF TIME MEASURING DEVICE:-

1. stop-watch or a stop-clock.
2. Simple pendulum: A point mass suspended by an inextensible, mass less string from a rigid point support. In practice a small heavy spherical bob of high density material of radius r , much smaller than the length of the suspension, is suspended by a light, flexible and strong string/thread supported at the other end firmly with a clamp stand.
3. Effective length of the pendulum: The distance L between the point of suspension and the centre of spherical bob.

PRINCIPLE :-

The simple pendulum executes Simple Harmonic Motion (SHM) as the acceleration of the pendulum bob is directly proportional to its displacement from the mean position and is always directed towards it.

The time period (T) of a simple pendulum for oscillations of small amplitude, is given by the relation

$$T = 2\pi\sqrt{L/g}$$

where L is the length of the pendulum, and g is the acceleration due to gravity at the place of experiment

can be re written as ,

$$g = \frac{4\pi^2 L}{T^2}$$

OBSERVATION TABLE AND CALCULATION:-

S. No.	Length of string in cm.	Time taken by pendulum to Complete 20 Oscillation in sec.		Average time taken in sec. $T = \frac{t_1 + t_2}{2}$	Time period of Pendulum $T = \frac{1}{t}$	Value of $\frac{L}{T^2}$ in cm/sec^2
		t_1	t_2			
1.						

RESULT:-

The value of $g = \underline{\hspace{2cm}} \frac{m}{\text{sec}^2}$

EXPERIMENT NO:- 4

DETERMINING THE RESISTANCE OF GIVEN WIRE BY METER BRIDGE.

AIM :-

To determine the resistance of a given wire using a metre bridge and hence determine the resistivity of the material of the wire.

APPARATUS AND MATERIAL REQUIRED:-

Metre bridge, a wire about 1m long (of material whose specific resistance is to be determined), a resistance box, a rheostat, galvanometer, a jockey, one-way key, a cell or battery eliminator, thick connecting wires, sand paper, screw gauge.

DESCRIPTION OF APPARATUS :-

Metre bridge It consists of one metre long constantan wire AC of uniform cross-sectional area mounted on a wooden board with a scale. The two ends of the wire are attached to terminals A and C.

Thick metal strips bent at right angles are used to provide two gaps E and F to connect resistors forming a Wheatstone's bridge. The terminal B between the gaps is used for connecting galvanometer and other end of the galvanometer is connected to a jockey J.

CIRCUIT FOR METER BRIDGE:-

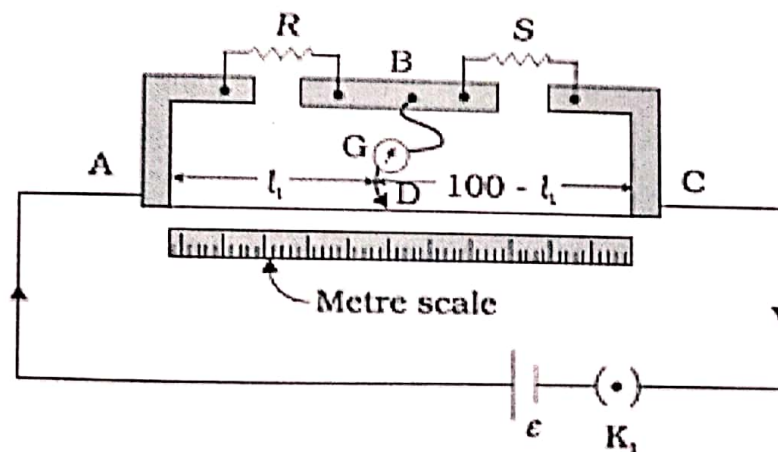

PRINCIPLE :-

A metre bridge works on the principle of Wheatstone's bridge. As shown in Fig. E 2.2, it consists of four resistors P, Q, R and S connected in the form of a

network ABCD. The terminals A and C are connected to two terminals of a cell through a key K1 . Terminals B and D are connected to a sensitive galvanometer G through a key K2 . If there is no deflection in the galvanometer G, then balance condition for Wheatstone's bridge is ,

$$\frac{P}{R} = \frac{Q}{S}$$

PRECAUTIONS :-

1. All the connections and plugs should be tight.
2. Jockey should be moved gently over the metre bridge wire.
3. The plug in the key (K1) should be inserted only at the time of taking observations.
4. Null points should be in the middle of the wire (30 cm to 70 cm).

EXPERIMENT NO: - 5

REFRACTING ANGLE OF RAYS IN A GLASS SLAB.

AIM :-

- 1). To determine refracting angle in a glass slab.
- 2). Proof that incident and refracting rays are mutually parallel in nature.

APPARATUS AND MATERIAL REQUIRED :-

Glass slab, blank white page, pins, pencil

DIAGRAM :-

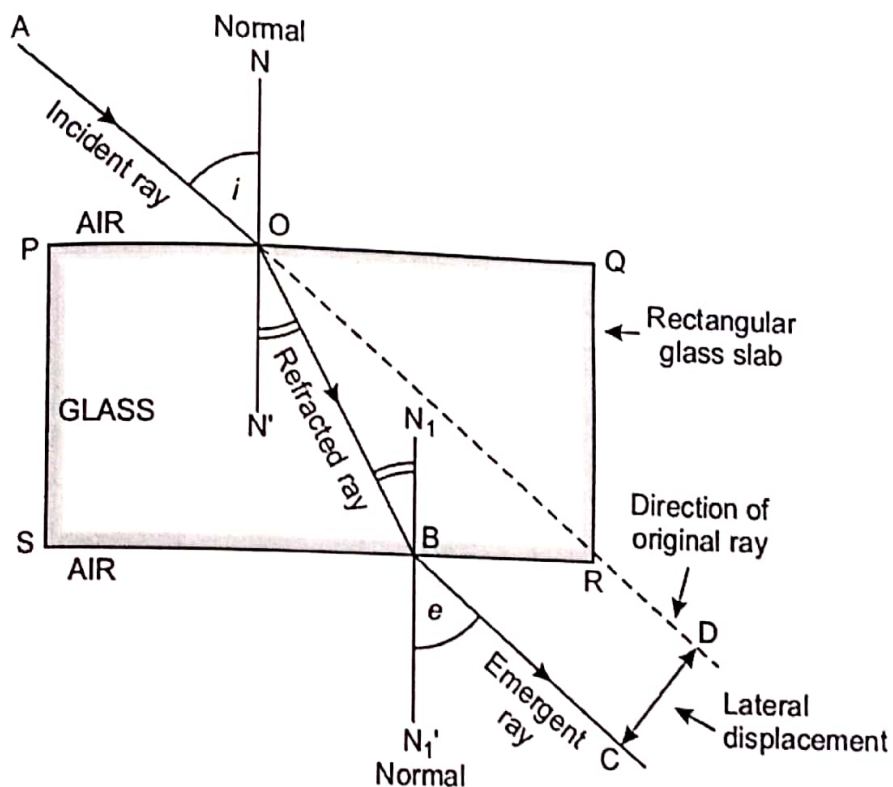

PRINCIPLE:-

Glass slab is a substance or sheet made of a glass material having 3 dimensions that is length breadth and height, it is cuboidal shaped. It does not deviate nor does it disperse the light rays passing through it.

This means that the incident and the emergent ray emerging from the glass slab are parallel. The glass slab only and only produces a lateral or (sideways) shift or displacement to the direction of light.

As we can observe and see below, the refraction or bending of light rays through a glass slab takes place at the two parallel and equal and opposite surfaces.

Through a glass slab, the light before coming back to the air suffers refraction two times. At the second time, the refracted ray bends away from the normal. If the light is incident at right angles then it will pass through the glass slab without any deviation. The emergent ray as we can see has emerged parallel to the before an incident ray of light. This is a characteristic property of a glass slab as it has two opposite and parallel equal faces from which the rays emerge.

Laws of Refraction

- We have the ratio of sin of angle of the incidence and refraction is a constant or has definite value. Which is stated as **Snell's law**

$$\frac{\sin i}{\sin r} = \text{constant}$$

- Where we have i = angle of incidence, r = angle of refraction, the constant value which depends upon the refractive indexes of the two taken mediums. It is their ratio and is dimensionless.

EXPERIMENT NO :- 6

REFRACTION THROUGH GLASS PRISM AND DETERMINING THE REFRACTIVE INDEX OF GLASS PRISM .

AIM-

1. To study the variation of angle of deviation (d) with angle of incidence (i) for a prism
2. To plot i-d curve
3. To determine the refractive index of the material of prism

APPARATUS

Glass prism, 4 pins , scale , protractor , prism board (drawing board)

THEORY

The refractive index of the material of prism is

$$\mu = \frac{\sin \frac{A+\delta}{2}}{\sin \frac{A}{2}}$$

where $D =$ the angle of minimum deviation (from i-d curve)

$A =$ the angle of prism

PROCEDURE :-

Fix a A4 sheet on a paper board , place prism and draw the boundary ABC. Then draw normal N (90° with AB) to the middle of side AB. From the meeting point draw a incident ray (PQ) at angle $i = \underline{\hspace{2cm}}$.

Fix two pin at P and Q (pins should be vertical with paper) on the incident ray. Place prism inside marking ABC. Close one eye and look through prism side AC. Fix two pin R and S such that all 4 pins seems to be in single line when looking through prism from side AC. After removing prism, extend lines RS such that they meet at O. find the angle of deviation (d) between lines as given in fig. Repeat the same for

$i =$ taking different angle .

OBSERVATION:-

S. NO.	Angle of incidence (i)	Angle of deviation (δ)
1.		
2.		
3.		

RESULT:-

1. when i increases d decreases first then increases
2. i - d graph plotted. The value of minimum deviation, $D = \dots\dots\dots$
3. The refractive index of the material of prism, $n =$

EXPERIMENT NO :- 7

DRAW MAGNETIC FIELD LINES OF FORCE BY USING BAR MAGNET.

AIM:-

1. To draw the magnetic field lines of force .
2. To verify the laws of magnetic field of force.

Material to be required :-

Blank sheet , pencil, bar magnet magnetic needle/ compass - compass is a simple device that consists of a permanent magnetic dipole that can rotate freely on top of a pin, and this dipole is called the needle.

When placed in a magnetic field, the north pole tends to move in the direction that a north monopole would, and likewise for the south pole. Clearly, this motion is highly constrained and stops once the needle is aligned with the local magnetic field.

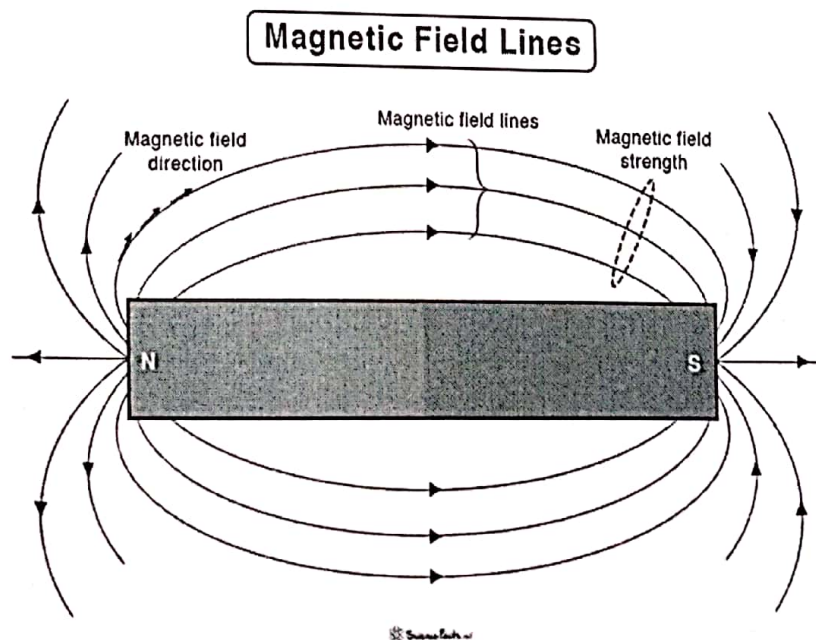

PRINCIPLE:-

Properties of magnetic field lines:

- They are drawn locally as parallel trajectories.
- They never intersect each other (if they do, it means that one pole is pointing in two directions).
- They start from North and terminate at South, outside the magnet, and vice-versa inside.

RESULT:-

- Plot the curves of magnetic field by joining the dots.
- Draw the magnetic field lines .